

# The Automatic Ultrasonic Washer E789



P.O. Box 734  
450 Taft Drive  
South Holland, IL 60473  
800-276-2466  
www.esmainc.com  
Email: sales@esmainc.com

# Features & Specs



## Cabinet Dimensions:

Tank module: 13" x 20"  
 Control module: 12" x 5"  
 Power module: 18" x 18" x 8"  
 Tank Dimensions: 13" x 11" x 11"  
 Tank Volume: 6.5 Gallons Ultrasonic  
 Power: 600 watts  
 Unit Power: 120vac, 15amp, 60hz  
 Counter cutouts:  
 Counter top: 18" x 11.25"  
 Cabinet front: 10.25" x 4.25"  
 Cassettes/load: 6 (8" x 11")  
 Cycle time: 28 minutes  
 UL Approved

Automatic Ultrasonic Washers are designed to simplify pre-sterilization instrument washing. The preprogrammed cycles are very similar to that of a dishwasher but our process incorporates high-powered ultrasonic cleaning and disinfecting technology. Esma's ultrasonic washers create a **hands-free** procedure that includes ultrasonic cleaning, ultrasonic rinsing and hot air drying. Included with the E789 is a chemical metering pump. This pump will automatically "meter" in the correct amount of detergent per wash cycle, eliminating the need to pour detergent concentrate into the tank during the fill cycle. Load it and push a button! It's just that simple and totally safe on instruments. *These counter-recessed, flush-mounted units require very little counter space and need no more installation than a sink, and they really perform! We have 15 years of in-field successful history.*

- Virtually eliminates hand scrubbing-risk to personnel is reduced as well as cross contamination that results from multiple ultrasonic cleanings in the same tank and cleaning solution.
- No more rinsing in the sink under running water-ultrasonic rinsing eliminates the inefficiencies of tap rinsing where dragout contaminants from the ultrasonic cleaner are never fully flushed away.
- No more open air towel drying-The messy drip trails created from ultrasonic-to-sink-to-counter are eliminated and the infection control area of the office is streamlined.

- 15 years of successful in-field history
- Powerful square wave ultrasonic circuitry
- 18 gauge welded stainless steel tank with lifetime warranty against leaks
- All stainless steel construction
- Unprecedented warranty
- PLC controlled, custom programming available
- Long-lasting potted transducers
- Single push-button activation
- Backed by quality assurance of underwriters labs

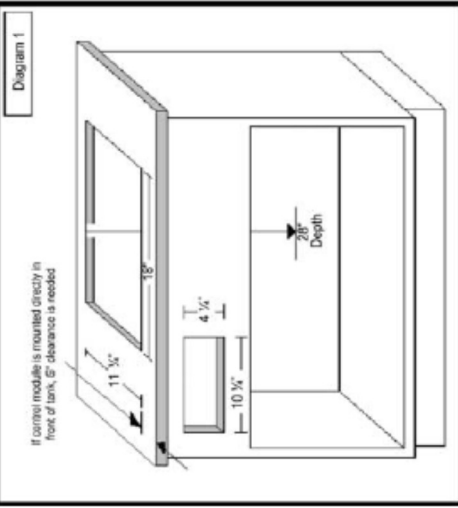

Ultrasonic washers can accommodate many different baskets or racking options. From large baskets for cleaning loose instruments to racks housing cassettes, our washers will fit into your instrument management system.



Consider using Esma Insertion Baskets as an alternative to cassettes. Insertion Baskets are designed to nest together enabling you to clean up to 12 at a time. These baskets are available in several sizes:

9 x 2.75 x 1.25	6.875 x 2.875 x 2.875
11.5 x 3 x 2.5	10 x 2.875 x 2.875
11.5 x 4.75 x 3	6.875 x 2.875 x 1.375

The E789 is equipped with a chemical metering pump for precision distribution of the exact amount of liquid detergent concentrate. Use only Esma brand detergent concentrates when operating the E789 with metering pump. Esma produces 3 powerful liquid cleaning agents:



Esma-Zyme E1204  
 Esma-Shine E105  
 Esma-General Purpose E589



*Celebrating over 30 years of excellence in manufacturing ultrasonic cleaning equipment, electropolishing equipment and associated chemistries*

## **Instructions for Ultrasonic Washer E789 (U.L. Approved)**

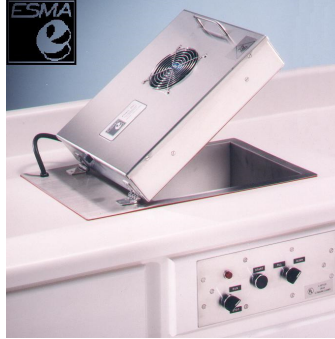

### **1. INTRODUCTION**

The E789 Automatic Ultrasonic Washer automatically performs a cleaning cycle, the major steps of which are:

- Ultrasonic cleaning
- Ultrasonic rinsing (hot tap water)
- Hot air drying

The E789 unit has a primary rinse solenoid, which is connected to the hot tap water supply. The E789 is equipped with a chemical metering pump for precision distribution of the exact amount of liquid detergent concentrate. ***Use only Esma brand detergent concentrates when operating the E789 with metering pump.*** The result is a finished product ready for the next step (sterilizing, packaging, assembly, storage). The unit consists of four sections: 1) **Tank Module**-to be installed in the counter 2) **Control Module**-to be installed in front of counter 3) **Power Module** to be installed under the counter and 4) **Metering Pump** which is to be located under counter.

**The Tank Module** is manufactured from 316 stainless steel with 12 potting transducers mounted on the bottom. The tank is equipped with two fill solenoids (E789 has only one), a drain solenoid and a low level control to prevent electronic damage if water pressure is lost. The tank is fitted with a 304 stainless hinged cover housing the fan and heater for air-drying.

**The Control Module** is manufactured from 304 stainless and contains the switches to start the FILL, CLEAN or FULL CYCLE cycles and stop the process manually, if needed.

**The Power Module** contains the self-tuning modular circuit boards, programmable controller, high velocity fan to cool the electronics and RFI filter to eliminate high frequency noise.



*Celebrating over 30 years of excellence in manufacturing ultrasonic cleaning equipment, electropolishing equipment and associated chemistries*

**The Metering Pump** is a Gorman-Rupp bellows metering pump. The supplied inlet tube from the metering pump should be inserted into a gallon jug of Esma cleaning solution concentrate. The pump is configured to “meter” a 1% concentrate during the fill cycle, approximately 180ml. Please use only proper detergent which is formulated for use with the E789 model.



PLEASE READ THESE INSTRUCTIONS THOROUGHLY BEFORE INSTALLATION AND OPERATION. CALL 800-276-2466 IF YOU HAVE ANY QUESTIONS

## 2. INSTALLATION

If the control module is to be placed directly in front of tank, allow 5 inches between counter opening and front of cabinet (diagram 1). Also, 28 inches of clearance is necessary under the counter for drains.

**Control Module** - Cut opening of 4 ¼” x 10 ¼” in front of cabinet. The overall flange of unit on front of cabinet is 5” x 12”, so center unit accordingly. Module will be mounted later with 4, No. 8 wood screws.

**Tank Module** - Cut opening of 18” x 11 ¼” in top of counter. The overall flange of unit on top of counter is 20” x 13”, so center unit accordingly. Place tank in opening and mark on counter the mounting studs welded under top plate. Remove tank and drill mounting holes with 1/4” drill bit. Do not mount tank until control module opening is cut out.

**Tank Module** should be set in counter first. A gasket is glued to the underside of the top plate to prevent liquid from seeping into the counter. Place the tank-mounting studs into the pre-drilled holes in counter and tighten down with 8 x 32 nuts and washers, which are supplied. (DO NOT OVERTIGHTEN).

**Power Module** measures 8’ x 16” x 18”D. However, 1” of clearance is necessary both at the front and back of unit for proper ventilation. The electrical connections, from tank and control modules, attached to the top of the module, require additional 2 to 3 inches of space.

**The Metering Pump** should be monitored to assure that there is solution in the jug. Due to the length of tubing, it will take one cycle for the metering pump to become “primed”. Once the pump is primed, a 1% solution concentrate will automatically be added to the water during the fill cycle. Please regularly check to make sure that there is adequate cleaning solution in the jug.

ESMA, Inc.

P. O. BOX 734 \* SOUTH HOLLAND, IL 60473 \* (800)-276-2466 \* FAX (708)331-8919



*Celebrating over 30 years of excellence in manufacturing ultrasonic cleaning equipment, electropolishing equipment and associated chemistries*

### **3. PLUMBING HOOK-UP**

#### **A. Water Input** (Diagrams 2 & 3, see last page)

The primary solenoid should be connected to a hot water source. This solenoid has a ½” NPT female opening. A ½”MNPT x ¾”MGH adapter has been supplied for hot water hookup using a standard washing machine water supply hose (not supplied). It is recommended that a filter washer be installed into the water supply hose to prevent sediment debris from entering solenoid from water source. The high-pressure hose should connect the solenoid to a shut-off valve (not supplied) at your water source. A flow regulator is incorporated into the unit; therefore, the shut-off valve must not restrict the flow more than 3.5 GPM.

Also, a backflow regulator (not supplied) may have to be attached at your water source to comply with local regulations.

#### **B. Water Output** (Diagram 2, see last page)

1½” x 16” elbow (A), which is supplied, is to be attached with a slip nut (B) and washer (C) to the 1½” output nipple. (This piece can be hooked up prior to installation of the tank but that is not necessary. The tailpiece (D) with ¾” input (supplied) is to be attached to elbow (A) with a slip nut (E) and adapting washer (F). Attached to the tailpiece, with a hose clamp (G), will be 2’ of ¾” hose (I). The other end of this hose is to be attached to be attached to hose adapter (H), with the hose clamp (G), after (H) is threaded into the drain solenoid using Teflon tape or joint compound. A “P” trap (not supplied) is then to be attached to tailpiece (D) prior to hookup to drain line.

### **4. ELECTRICAL**

The unit is rated at 1500 W, 120 VAC, 50/60 HZ. Only the power module is plugged into your 120VAC supply (diagram).

The Tank Module has two plugs. Both plugs are attached to power module at receptacles C & E.

Control Module plug (M) plugs into power module receptacle (G). Only the plug from power module (A) is to be connected to your power source. Unit must be electrically grounded. The power cord must be connected to a three-way grounded outlet. For 2-wire service, an adapter with external ground wire is necessary. Connect the green grounding wire of the adapter to the



*Celebrating over 30 years of excellence in manufacturing ultrasonic cleaning equipment, electropolishing equipment and associated chemistries*

screw, which holds the electric outlet plate cover to the socket. DO NOT OPERATE UNIT WITHOUT PROPER GROUNDING. A fuse, 15AMP, 120VAC, is located on the power module.

## 5. CONTROL FUNCTION

**A. Main Switch:** When unit is ready for operation, put the main switch to ON and the indicator light on the power and the Control Module will be **ON**.

**B. Run-Stop Switch:** Located on Control Module, must be in the RUN position for the programmable controller to operate. If during the program cycle you want to stop the process, turn switch to STOP position and the program cycle will discontinue. Move switch back to RUN position and program will START over at the beginning of the fill cycle when start button is pushed.

**Use run-stop switch only for emergency stopping of unit.**

### **C. Fill/Clean/Full Cycle Switch:**

**Fill:** When the Fill cycle is selected and the START button is pushed the tank will fill and hold with heated detergent. Use this cycle if you do not have a full load of instruments and you would like to soak them until ready to complete the cycle.

**Clean:** Select Clean cycle only after the fill step above has been run. Pressing START when there is a full load of instruments will complete the clean/rinse/dry cycle. You cannot start the clean cycle if the fill cycle (above) is not completed first.

**Full Cycle:** When Full Cycle is selected and the START button is pushed the unit will fill with heated detergent and continue automatically with the clean/rinse/dry steps.

This is a safety precaution so the ultrasonics will not operate without any liquid in the tank.



*Celebrating over 30 years of excellence in manufacturing ultrasonic cleaning equipment, electropolishing equipment and associated chemistries*

## **6. PRELIMINARY START-UP**

After plumbing is completed, conduct the following test to determine if there are any leaks in the system.

- A. Turn main power ON
- B. RUN-STOP switch to ON
- C. FILL/CLEAN switch to FILL
- D. Close cover

Push START button and gradually open the inlet valve you installed in the rinse line to bleed the air out of the line; then immediately open valve completely. The unit has a flow control valve which allows 3.5GPM, so it is important that the inlet valve doesn't restrict the flow to less than 3.5GPM or the fill time will have to be increased. After 90 seconds, the fill solenoid will close, and the water will be up to the overflow drain opening. Possibly, the first time the inlet valve was not manually opened fast enough to allow 3.5GPM for the entire 90 seconds. To test the overflow-rinse line, leave FILL/CLEAN switch on FILL and push the start button and water will flow into tank for additional 90 seconds. Now you can check your plumbing for leaks.

**CAUTION:** When conducting this leak test, make sure the power module is not under the plumbing in order to avoid getting the electronics wet.

To test the drain plumbing, move FILL/CLEAN switch to CLEAN and push START button to start the ultrasonic cleaning cycles (make sure fan inlet and outlet of power module are not obstructed). The clean cycle will cavitate for 10 minutes before the tank will drain. The entire clean cycle and times are given in the procedure section. You can stop the clean cycle at any time by turning the RUN-STOP switch to STOP and the program will revert back to the beginning of the FILL CYCLE.



*Celebrating over 30 years of excellence in manufacturing ultrasonic cleaning equipment, electropolishing equipment and associated chemistries*

## 7. OPERATION

The basic principle of operation is the enhancement and acceleration of the cleaning action through ultrasonic cavitations. Instruments, or parts to be cleaned, are placed in the basket (or cassette racks) and lowered into the tank.

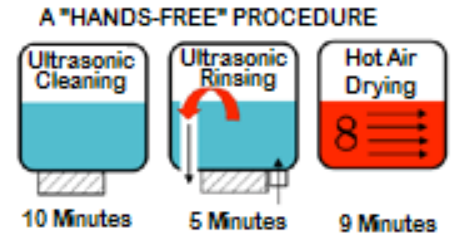

NEVER PLACE PARTS DIRECTLY ON THE BOTTOM OF THE TANK.

The baskets and cassette racks have rubber supports to keep parts off bottom of tank.

## 8. PROCEDURE

1. Turn main power ON
2. Turn RUN-STOP switch to RUN. (Should remain in RUN position at all times.
3. Set FILL/CLEAN switch to FILL.
4. Verify that the metering pump inlet supply is inserted into a gallon jug of an approved Esma cleaning concentrate (see section on cleaning agents).
5. Lower basket with instruments, or parts, on support rack.
6. Close cover.
7. Push START button and water will enter the tank for 90 seconds.
8. At this point more instruments (or parts) could be added when available, or move FILL/CLEAN switch to CLEAN, push START button and the cleaning program will automatically proceed through the cycle as follows:



*Celebrating over 30 years of excellence in manufacturing ultrasonic cleaning equipment, electropolishing equipment and associated chemistries*

**E789 UNIT**

<b><u>Function</u></b>	<b><u>Time/Seconds</u></b>
1. Fill with hot water and Detergent concentrate	60
2. Fill with hot water only	30
3. Ultrasonic cleaning	600
4. Drain	180
5. Fill	90
6. Ultrasonic	60
7. Ultrasonic/Rinse	60
8. Ultrasonic	60
9. Ultrasonic/Rinse	60
10. Ultrasonic	60
11. Drain	150
12. Drain, Dryer, Fan	420
13. Drain, Fan	120
14. Buzzer	5
	TOTAL 1835 seconds
	(30 ½ minutes)

**9. WATER CONSUMPTION**

In the program, 5 gallons of water are used on the initial fill cycle with an additional 12 gallons used in the fill-rinse steps, C to H, for a total of 17 gallons of hot water used per cycle.

If any changes in the rinse programs are required, consult the manufacturer.

**10. DRYING**

Incoming air is heated in the tank cover to 160° F and forced by the fan through the tank chamber before exhausting through the tank cover. CAUTION: Do not touch the cover during the drying cycle because some areas will be hot. Also, NEVER place any towel or obstruction over the fan intake on cover. After 7 minutes of hot air drying, the parts are left in the tank for 2 minutes to allow some cooling to take place before handling. The air temperature during the hot air drying can be increased or decreased by adjusting a thermo-switch located in dryer cover at hot air exit. Please contact manufacturer for more details.



*Celebrating over 30 years of excellence in manufacturing ultrasonic cleaning equipment, electropolishing equipment and associated chemistries*

## **11. PRESOAKING OF INSTRUMENTS**

For maximum effective cleaning, it is best if blood and other substances do not dry on the instruments. Therefore, fill the tank with hot water and cleaning agent and use the tank as a holding vessel for instruments until enough have accumulated to warrant cleaning.

## **12. CLEANING AGENT**

***Use only Esma brand detergent concentrates when operating the E789 with metering pump.*** Esma produces 3 powerful liquid cleaning agents:

- Esma-Shine E105
- Esma-General Purpose E589
- Esma-Zyme E1240.

DO NOT use powdered detergents; some powders take too long to go into solution. The metering pump is engineered to pump only the correct amount of detergent concentrate into the tank during the fill cycle. Esma brand detergents are formulated to meet the pump ratios. The metering pump has been factory calibrated to meter in 180ml of detergent concentrate during the fill cycle. By not using the correct cleaning agent problem can arise with final rinsing of parts if too much suds are generated.

## **13. LOW LEVEL SENSOR**

A low-level safety device is installed on the tank module to assure that the ultrasonics will not come on if there is less than three inches of water in the tank. A stainless probe is fixed in a Teflon plug mounted on the tank wall. When the liquid in the tank covers the probe the ultrasonics will activate during the clean or rinse cycles. Periodically, the probe should be wiped off to prevent insulating residues from cleaning agents, etc. from accumulating.

## **14. PROGRAMMABLE CONTROLLER**

An Omron CPM-20CDR programmable controller (PLC) is used to control the FILL and CLEANING process. A peripheral device (C200h-PRO27-E) is available to change the program or modify the times of the process. The memory protection maintains the program during power interruptions and a flash memory backup will save the program for 20 days at an ambient temperature of 77°F. PLC status indicators, located on top of the PLC, show the operating status according to the following table:



*Celebrating over 30 years of excellence in manufacturing ultrasonic cleaning equipment, electropolishing equipment and associated chemistries*

Indicator	Status	Meaning
POWER (green)	ON	Power is being supplied to the PLC.
	OFF	Power isn't being supplied to the PLC.
RUN (green)	ON	The PLC is operating in RUN or MONITOR mode.
	OFF	The PLC is in PROGRAM mode or a fatal error has occurred.
ERROR/ALARM (red)	ON	A fatal error has occurred. (PLC operation stops.)
	FLASHING	A non-fatal error has occurred. (PLC operation continues.)
COMM (orange)	ON	Data is being transferred via the Peripheral Port.
	OFF	Data isn't being transferred via the Peripheral Port.

## 15. MAINTENANCE

Periodically, the drain screen in tank will have to be removed and cleaned. The accumulated lint and debris could slow down the draining enough so tank will not be emptied of cleaning solution when rinse cycle begins.

Once a month, open power module and vacuum any dust that might have been drawn in by the fan. Never operate unit with cover of power module off.

The tank is manufactured of 316SS and the modules of 304SS. Clean with a commercially available cleaner for stainless steel kitchen appliances.

FOR ASSISTANCE CALL 800-276-2466 or 708-331-1855

## 16. TROUBLE SHOOTING

- If there seems to be erratic behavior with a component, or if the fill and/or clean cycle seem to have changed, always go through the following procedure:
  - Turn RUN-STOP switch momentarily to STOP and then back to RUN. The program will now clear and revert to the beginning calling for a FILL CYCLE. Move FILL-CLEAN switch to FILL and push START regardless of if the tank has water in it.
  - If the problem persists, continue with trouble shooting or call manufacturer.
- If there is still a problem, look at the PLC located in the Power module. With MAIN switch ON and RUN-STOP in RUN position. Make sure that the POWER and RUN lights are ON.



*Celebrating over 30 years of excellence in manufacturing ultrasonic cleaning equipment, electropolishing equipment and associated chemistries*

<b>PROBLEM</b>	<b>CAUSE</b>	<b>REMEDY</b>
Rinse solenoid is noisy, pulsating and little or no water coming into tank when output 00 is ON	Particles or other accumulation has entered bleed line of solenoid  Low water pressure	Solenoid needs to be cleaned out (see instruction sheet for fill solenoid) Make sure filter screen is in place prior to valve  5-10 PSI water pressure is required to operate solenoid
No ultrasonics when output 01 is ON. Large cooling fan in power module is ON.	Fuse blown on circuit boards.	Need repair—check that cooling fan is operating during cleaning.
No ultrasonics when large cooling fan is OFF when output 01 is on	Low water level in tank has activated low level safety control  Rise solenoid problem, or insufficient water supply.  In line fuse to PLC is blown.  Relay for fan and circuit boards not working.  Low-level safety control is faulty.	As above (fill solenoid problem)  Replace 1.5Amp/120V fuse  Replace relay  Clean deposit off probe  Contact manufacturer
Dryer gets too hot	Fan inlet on top off cover is blocked  Thermostat inside cover needs adjustment  Dryer Fan not working with output 06 on	Remove obstacle  Contact manufacturer  Replace in-line fuse to PLC
Dryer is cool with output 03 ON	Thermostat needs adjustment if there is some heat.  Relay in control module is faulty	Contact manufacturer  Replace relay
Tank drains with output 02 OFF	Debris lodged in drain solenoid	Clean out solenoid (see instructions) and make sure drain screen in place in tank
Tank does not drain with output 0N	Drain screen clogged.  Y strainer clogged  Solenoid not operating	Clean and replace screen.  Clean out Y strainer  In-line fuse to PLC is blown or clean out solenoid valve



*Celebrating over 30 years of excellence in manufacturing ultrasonic cleaning equipment, electropolishing equipment and associated chemistries*

## INSTALLATION INSTRUCTIONS & CABINET REQUIREMENTS FOR ULTRASONIC WASHER MODEL E789

### 1. INTRODUCTION

The units automatically perform a cleaning cycle, the major steps of which are:

- Ultrasonic cleaning
- Ultrasonic rinsing (hot tap water)
- Ultrasonic rinsing (deionized water)-unit E291 only • Hot air drying

The E789 unit has only one rinse solenoid (primary), which is connected to the hot tap water supply.

The result is a finished product ready for the next step (sterilizing, packaging, assembly, storage).

The unit consists of three sections: 1) **Tank Module**-to be installed in the counter 2) **Control Module**-to be installed in front of counter and 3) **Power Module**- to be installed under the counter.

**The Tank Module** is manufactured from 316 stainless steel, with 12 potting transducers mounted on the bottom. The tank is equipped with two fill solenoids (E789 has only one), a drain solenoid and a low level control to prevent electronic damage if water pressure is lost. The tank is fitted with a 304 stainless hinged cover housing the fan and heater for air-drying.

**The Control Module** is manufactured from 304 stainless and contains the switches to start the FILL or CLEAN cycles and stop the process manually, if needed.

**The Power Module** contains the self-tuning modular circuit boards, programmable controller, high velocity fan to cool the electronics and RFI filter to eliminate high frequency noise. PLEASE READ THESE INSTRUCTIONS THOROUGHLY BEFORE INSTALLATION AND OPERATION. CALL (800) 276-2466 IF YOU HAVE ANY QUESTIONS.

### 2. INSTALLATION

If the control module is to be placed directly in front of tank, allow **5** inches between counter opening and front of cabinet (diagram 2). Also, 28 inches of clearance is necessary under the counter for drains.

**Control Module**-Cut opening of 4-1/4" x 10 1/4" in front of cabinet. The overall flange of unit on front of cabinet is 5" x 12", so center unit accordingly. Module will be mounted later with 4 No. 8 wood screws.

**Tank Module**-Cut opening of 18" x 11-1/4" in top of counter.

The overall flange of unit on top of counter is 20" x 13", so center unit accordingly. Place tank in opening and mark on counter the mounting studs welded underneath top plate. Remove tank and drill mounting holes with 1/4" drill bit. Do not mount tank until control module opening is cut out.

**Tank Module** should be set in counter first. A gasket is glued to the underside of the top plate to prevent liquid from seeping into the counter. Place the tank-mounting studs into the pre-drilled holes in counter and tighten down with 8 x 32 nuts and washers, which are supplied. (DO NOT OVERTIGHTEN).

**Power Module** measures 8" x 16" x 18" D. However, 1" clearance is necessary both at the front and back of unit for proper ventilation. The electrical connections from tank and control modules, attached to the top of the module, require additional 2 to 3 inches of space.

### 3. PLUMBING HOOK-UP

#### A. Water Input (Diagrams 3, 4 & 5, see last page)

The primary solenoid should be connected to a hot water source. This solenoid has a 1/2" NPT female opening. An adapter and a high-pressure hose, with a filtered washer are supplied. The high-pressure hose should connect the solenoid to a shut-off valve (not supplied) at your water source. A flow regulator is incorporated into the unit, therefore, the shut-off valve must not restrict the flow more than 3.5 GPM.

Also, a backflow regulator (not supplied) may have to be attached at your water source to comply with local regulations. On Model E291 only, a deionized water source is connected to the secondary solenoid following the instructions given for the primary solenoid (Diagram 5).

#### B. Water Output (Diagram 3, see last page)

1 1/2" x 16" elbow (A), which is supplied, is to be attached with a slip nut (B) and washer (C) to the 1 1/2" output nipple. (This piece can be hooked up prior to installation of the tank but that is not necessary).

The tailpiece (D) with 3/4" input (supplied) is to be attached to elbow (A) with a slip nut (E) and an adapting washer

(F). Attached to the tailpiece, with a hose clamp (G), will be 2' of 3/4" hose (1). The other end of this hose is to be attached to hose adapter (H), with the hose clamp (G), after (H) is threaded into the drain solenoid using Teflon tape or joint compound.



*Celebrating over 30 years of excellence in manufacturing ultrasonic cleaning equipment, electropolishing equipment and associated chemistries*

A "P" trap (not supplied) is then to be attached to tailpiece (D) prior to hookup to drain line.

## 4. ELECTRICAL

The unit is rated at 1500 W, 120 VAC, 50/60 HZ. Only the power module is plugged into your 120 VAC supply (diagram 4).

**The Tank Module has two plugs.** Plug (K) goes to the under side of Control Module and attaches to receptacle (L). Plug (I) is attached to power module at receptacle (E).

**Control Module** has two plugs, (M) and (N), which attach to receptacles (C) and (G) on the power module.

**Only the plug from power module (A)** is to be connected to your power source. Unit must be electrically grounded. The power cord must be connected to a three-way grounded outlet. For 2- wire service, an adapter with external ground wire is necessary. Connect the green grounding wire of the adapter to the screw, which holds the electric outlet plate cover to the socket. **DO NOT OPERATE UNIT WITHOUT PROPER GROUNDING.** A fuse, 15 AMP 120 VAC, is located on the power module.

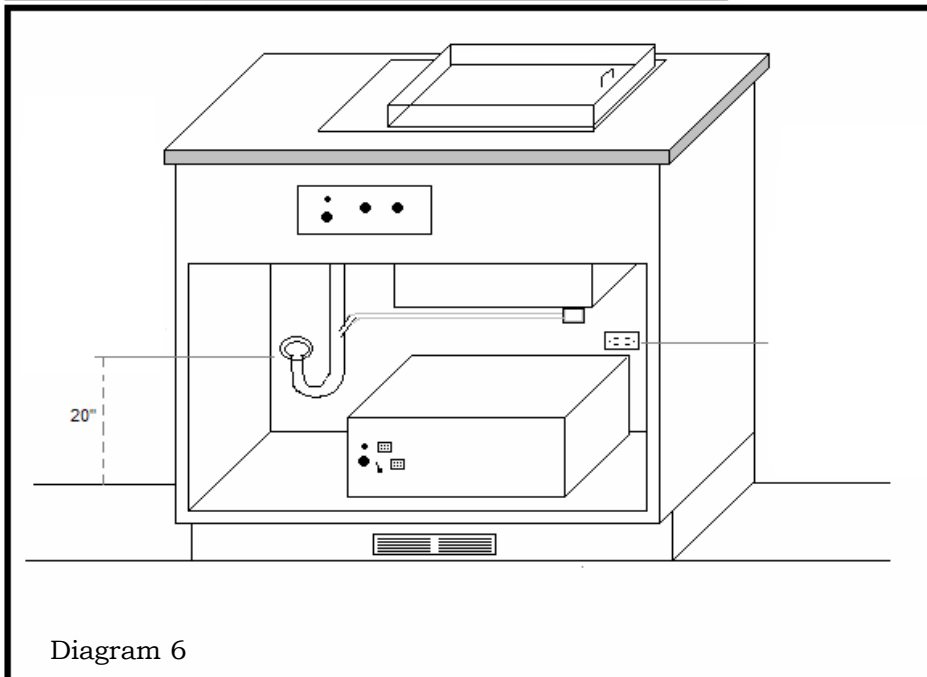
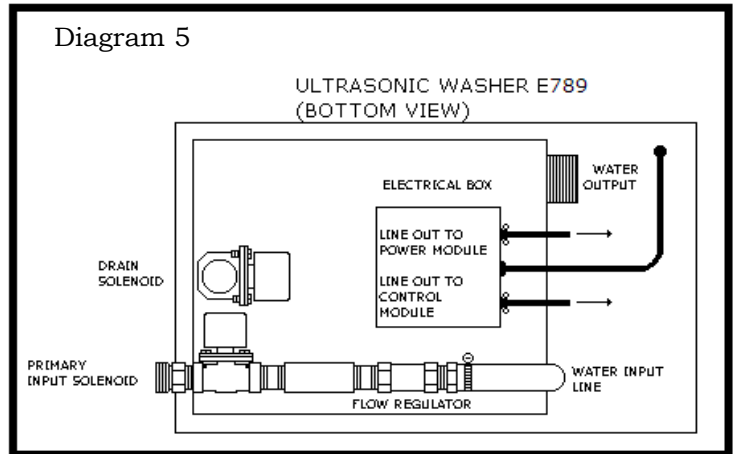
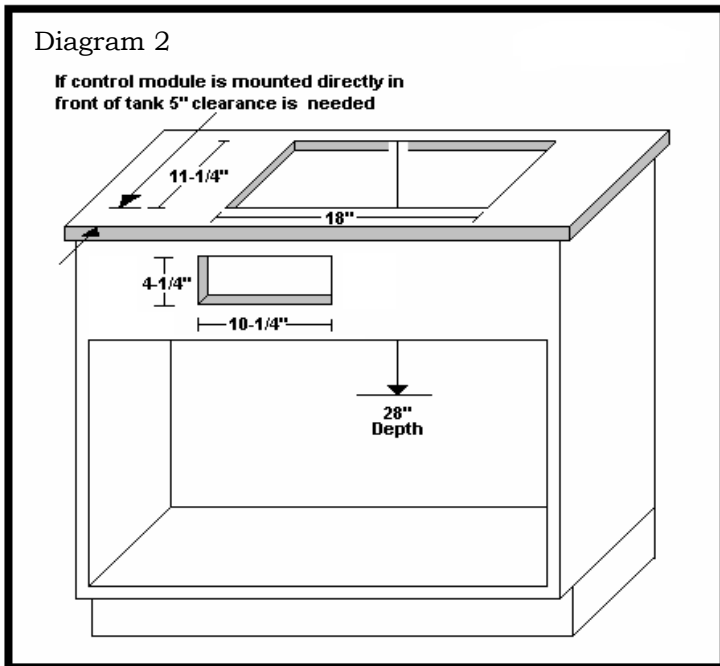
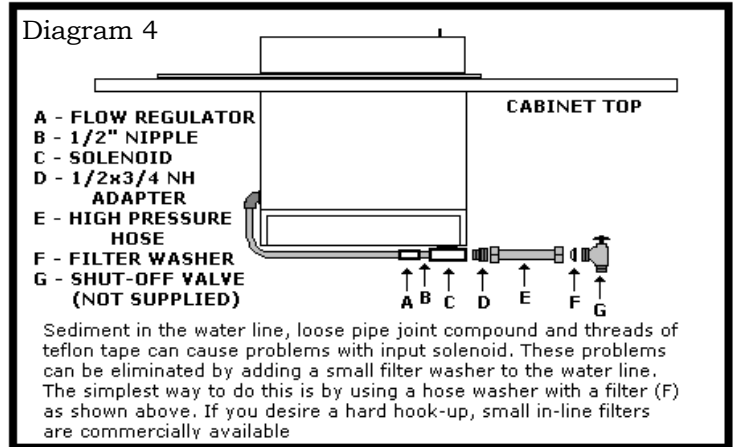
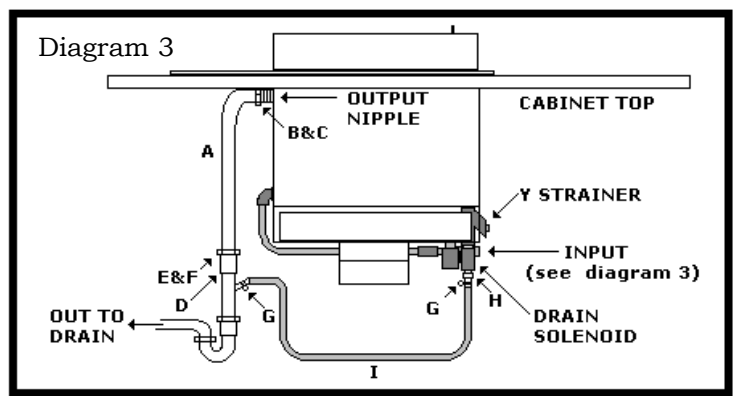
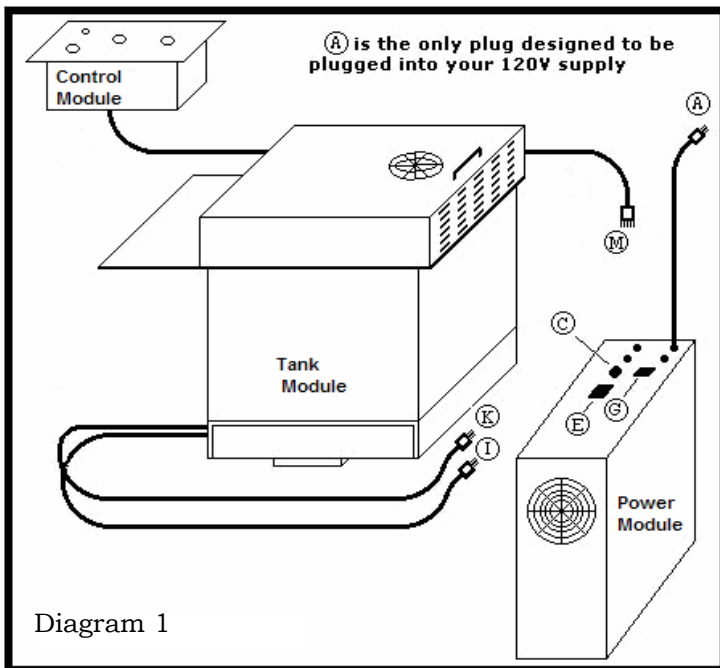



*Celebrating over 30 years of excellence in manufacturing ultrasonic cleaning equipment, electropolishing equipment and associated chemistries*

## **ACCESSORIES**

Included with your E789 Unit are the following accessories for installation.

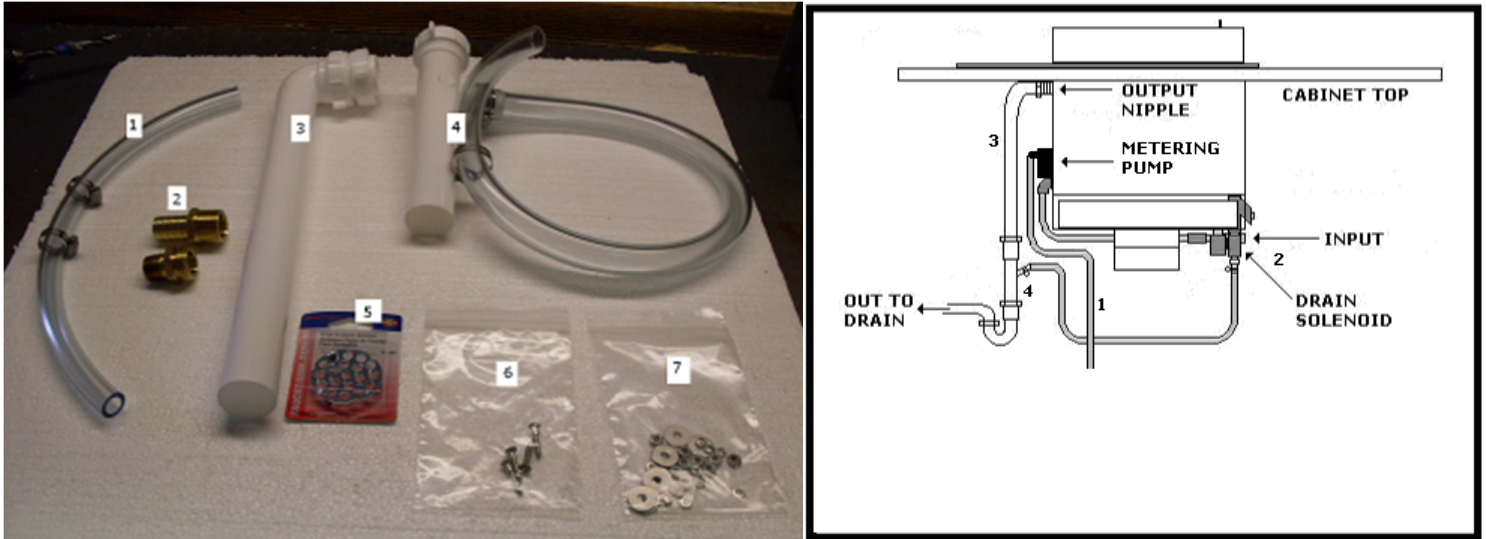

1. ½" tubing to be inserted on the METERING PUMP barbed fitting and secured with supplied hose clamps. This tube is to be inserted into a gallon jug of detergent.
2. Brass fittings for INPUT valve and DRAIN SOLENOID
3. PVC Waste Arm. Connects to OUTPUT NIPPLE in
4. Branch Tailpiece. Connects to waste arm (3) and tubing connects to DRAIN SOLENOID brass fitting
5. Overflow drain screen
6. Control Module mounting screws
7. Tank mounting screws